



User manual

küschall[®] K-Nova

CE

Table of contents

1 General	3	5 Service.....	18
1.1 Introduction	3	5.1 Cleaning.....	18
1.2 Warning and instruction signs	3	5.2 Maintenance	18
1.3 Description of the wheelchair	3	5.3 Service life and disposal	20
1.4 Use as per specifications	3	5.4 Detecting and repairing defects	21
1.5 Before using the wheelchair	3	5.5 Technical data.....	22
2 Using the wheelchair.....	4	5.6 Warranty conditions.....	23
2.1 Sitting down / getting up	4	6 Adjustments carried out by the authorized dealer	24
2.2 Driving and steering the wheelchair	4	6.1 Back height adjustment.....	24
2.3 Driving over stairs and steps	5	6.2 Backrest angle adjustment.....	25
2.4 Driving on ramps and slopes.....	7	6.3 Vario-Ax Adjustment.....	25
2.5 Stability and balance when sitting in the chair	8	6.4 Rear Wheel Position.....	26
2.6 Parking brakes.....	9		
3 Transporting the wheelchair	11		
3.1 Folding and unfolding the wheelchair	11		
3.2 Removing and installing the rear wheels	12		
4 Adjustments and options.....	13		
4.1 Adjusting the parking brakes.....	13		
4.2 Adjusting the tension of the backrest cover	13		
4.3 Height adjustable push handles	14		
4.4 Foldable Push handles	14		
4.5 Armrest	15		
4.6 Mudguards	15		
4.7 Transit wheels.....	15		
4.8 Antitipper.....	16		
4.9 Security belt	17		
4.10 Passive lighting	17		
4.11 Air pump.....	17		



- ① Front frame
- ② Seatmodule
- ③ Axle tube
- ④ Rear wheel
- ⑤ Backrest
- ⑥ Footrest
- ⑦ Front wheel

Figure 1

1 General

1.1 Introduction

Thank you for purchasing a *küschall*® wheelchair.

With the *küschall*® *K-Series* you have purchased a top-quality product. In order to make optimum use of its functionalities and learn about its safety requirements, please read these operating instructions carefully and follow the safety instructions.

1.2 Warning and instruction signs

The following signs and abbreviations are used in these operating instructions:



Warning sign containing important information to prevent injuries and material damage.



Useful information for user



Required tool: Hexagon socket wrench 3mm



Required tool: Wrench 8mm



Required tool: Screw driver

The drawings in this manual show wheelchairs in different configurations. Your wheelchair configuration may differ from the pictured one.

1.3 Description of the wheelchair

The wheelchair consists of a rigid frame ① onto which the seat module ② and the foldable backrest ⑤ are attached. Both the left and the right side frame are attached to an axle tube ③. The rear wheels ④ are mounted to the frame with rear wheel fixture elements. The front wheels ⑦ as well as the footrest ⑥ are fixed to the front frame. (See figure 1)

1.4 Use as per specifications

The wheelchair is driven manually and is used for independent or guided locomotion of gait-impaired persons (e.g. hemiplegia, paraplegia, tetraplegia, multiple sclerosis, traumatic brain injury, etc.). The wheelchair may only be used without a guide by persons who are physically competent to handle the wheelchair (e.g. driving, steering and braking). The wheelchair is designed for in- and outdoor use on level ground and pathed terrain.

1.5 Before using the wheelchair



Before using the wheelchair for the first time, please read Chapter 2 - *Using the wheelchair* carefully and follow the safety instructions.

For security reasons it is essential that you check the functionality of your wheelchair daily. Pay special attention on the following parts (provided they are mounted): Wheels, backrest, antitipper, pushhandles, quick release fork.

Normally, your authorized dealer will unpack and unfold the wheelchair if necessary for you. If you receive your wheelchair unfolded, please read Chapter 3.1 - *Folding and unfolding the wheelchair*.

2 Using the wheelchair



Always adjust the clothes you wear and your driving behaviour to the conditions (weather, road conditions, individual skills etc.).

Please note that the risk of sliding is higher if the ground is wet, on gravel roads and on rough ground.

2.1 Sitting down / getting up



When getting in or out of the wheelchair, do not stand on the footrests. Danger of tipping!

You should only get on/off the wheelchair if you are physically competent. Please consult your physician or therapist.

Do not sit on the brakes, the mud guard or the armrest when getting on/off the wheelchair. They might bend or break. Danger of injury!

The method you use to transfer in and out of your wheelchair will depend on your own capabilities. Generally, the procedure is as follows:

- Pull the parking brake
- Hold on to the wheelchair and, if necessary, to a stable object nearby.

2.2 Driving and steering the wheelchair

Finding the tipping point

The tipping point of the wheelchair depends on the adjustment of the seat position. The correct seat position is adjusted depending on parameters such as the weight of the user, the type of handicap and the driver's driving skills. The seat position which is adjusted upon delivery corresponds to the information indicated in your order.

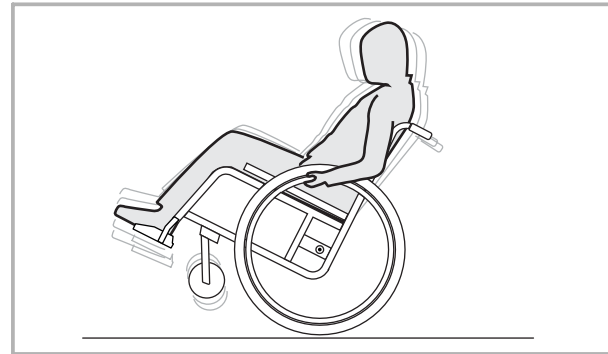

Figure 2

To find the tipping point of your wheelchair, proceed as follows (see Figure 2):



When determining the tipping point, an aide must always stand directly behind the wheelchair in order to catch it in case it tips.

To ensure that you are in control of your wheelchair at any given point, you should not exceed a speed of 7km/h. (4Mph)

- Loosen the brakes
- Sitting in the wheelchair, move forwards briefly, hold both hand rims tightly and pull back with a slight swing.
- By shifting your weight slightly and applying a counter-force to the hand rims, the tipping point can be determined.



To avoid the wheelchair tipping backward, we recommend that the wheelchair should be equipped with an antitipper (see Chapter 4).

Please note that a heavy backpack fixed to the backrest can affect the tipping behaviour of the wheelchair.



The position of the seat module influences the balance and the tipping tendency of the wheelchair. The centre of gravity must be re-defined after adjustments have been made.

2.3 Driving over stairs and steps



Always be very careful and move slowly when driving over curbstones, stairs or other steps.

Do not try to drive over steps which have a height of more than 25 cm.

Only drive on stairs with more than one step if an aide is behind the wheelchair.

With an aide



Figure 3

Driving down a step

- Drive to the edge of the step, make sure that the wheelchair is in a straight position.
- Hold on to the two push handles on the rear of the wheelchair and tilt backward so that the front wheels leave the ground.
- Hold the wheelchair in this position and push it down the step slowly. The wheelchair driver can support you by using the hand rims.

- Tilt the wheelchair forward until the front wheels have ground contact again.

Driving up a step



Do not lift the wheelchair by the backrest bar.

- Move the wheelchair backward until the rear wheels hit the edge of the step.
- Pull back both push handles, tilt the wheelchair until the front wheels leave the ground and pull the rear wheels over the edge.
- Move the wheelchair until you can safely tilt the wheelchair forward and the front wheels have ground contact again.

Without an aide



If you want to drive down a step without a guide, you must have perfect control over your wheelchair and must be able to balance it on the rear wheels. (see Finding the Tipping Point in Chapter 2.2).

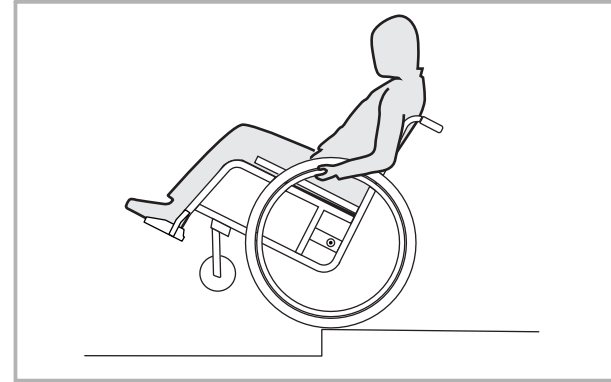

Figure 4

Driving down a step

- Drive to the edge of the step, make sure that the wheelchair is in a straight position.
- Lift up the front wheels from the floor by shifting your body weight and keep your balance.
- Now let the two rear wheels roll down over the edge. Make sure to hold the hand rims tightly.
- Tilt forward the wheelchair until the front wheels have ground contact again.

Driving up a step

- Drive the wheelchair backward until the rear wheels hit the edge of the step.

- Lift up the front wheels from the floor by shifting your body weight and keep your balance.
- Now let the two rear wheels roll up over the edge. Make sure to hold the hand rims tight.
- Move the wheelchair until you can tilt the wheelchair forward safely.
- Lower the front wheels again.

2.4 Driving on ramps and slopes



Only drive on long slopes if a guide is behind the wheelchair.

Do not drive on steep or lateral slopes (max. ascending grade 7°). Danger of tipping!

Avoid abrupt changes of direction when driving on slopes. Danger of tipping!

Never pull the parking brakes when the wheelchair is in motion. Danger of tipping!

Driving uphill

To drive uphill you must set the wheelchair in motion and maintain the motion in order to be able to control the direction.

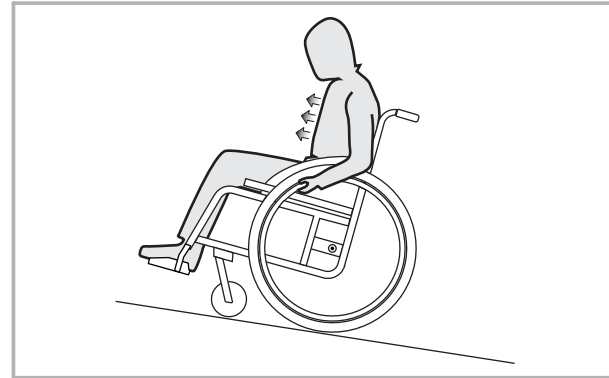

Figure 5

- Lean forward and drive the wheelchair by pushing the hand rims quickly and powerfully.

Downhill

When driving downhill, direction and, above all, speed must be controlled.

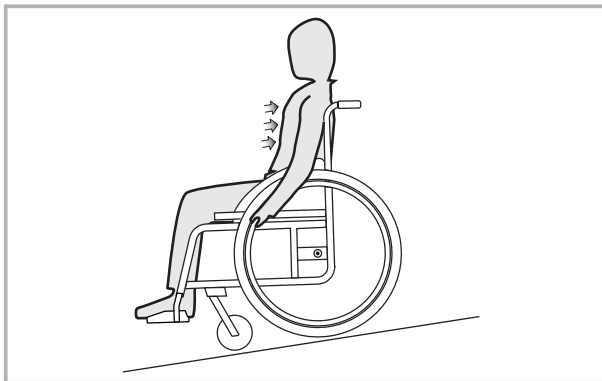

Figure 6

- Lean back and let the hand rims slip through your hands carefully. You should be able to stop the wheelchair at any time by holding the hand rims.



Please note that, the hand rims can heat if you brake for longer periods of time by hand. This applies especially to MaxGrepp and Supergripp handrims

2.5 Stability and balance when sitting in the chair

For many every day life activities you will have to bend out of the wheelchair, forwards, to the side or backwards. This has a great influence on the stability of the wheelchair. In order to keep your balance at any time, please observe the following:

Leaning forward

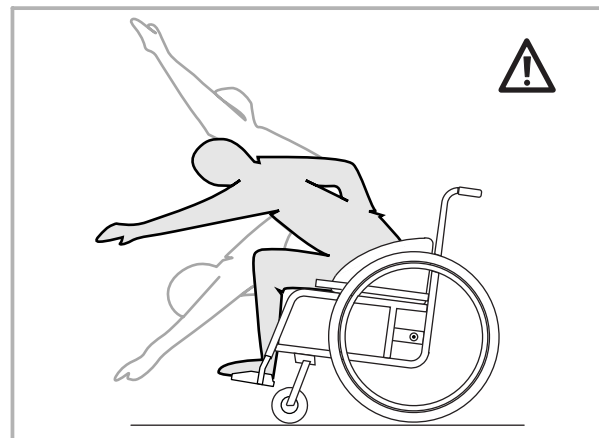

Figure 7

- Align the front wheels to the front. (To do this, move the wheelchair slightly forward and then back again.)
- Apply both parking brakes.
- When leaning forward, make sure that your abdomen remains above the front wheels.



Do not lean forward too much. You might fall out of the wheelchair!

Do not slide forward in your seat to reach out for remote objects. You might fall out of the wheelchair!

Do not try to bend your abdomen forward between your legs in order to pick up something from the floor.

Leaning backward

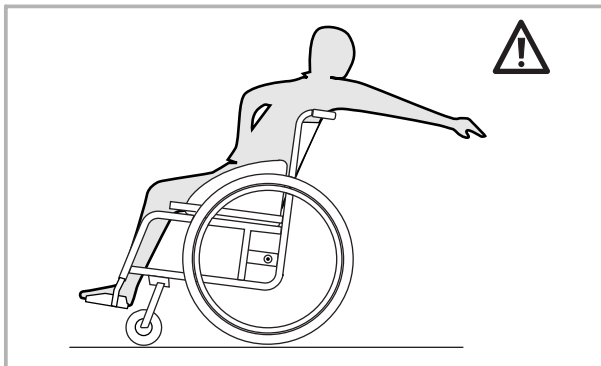

Figure 8

- Align the front wheels to the front. (To do this, move the wheelchair forward a bit and then back again.)
- Do not apply the parking brakes.
- Reach out backward only as much as possible without leaving your sitting position.



Do not lean over the backrest. You might tip backward.

2.6 Parking brakes

If your wheelchair is not equipped with a drum brake, deceleration is effected manually by applying force on the hand rims of the rear wheels. The parking brakes are used only for keeping the wheelchair in place when standing and to prevent it from rolling away. The correct function of the parking brakes is ensured only if sufficient air is in the tire. (see Chapter 5.2 - Maintenance)



Never apply the parking brakes when the wheelchair is in motion - Danger of tipping!

Standard brake

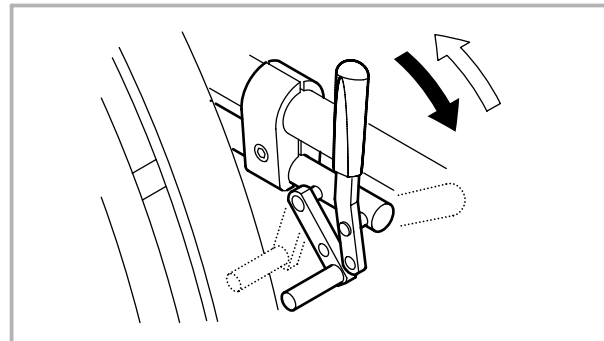

Figure 9

Applying the brake

- Push the brake lever forward until it reaches the stopper.

Releasing the brake

- Pull the braking lever back.

Performance brake

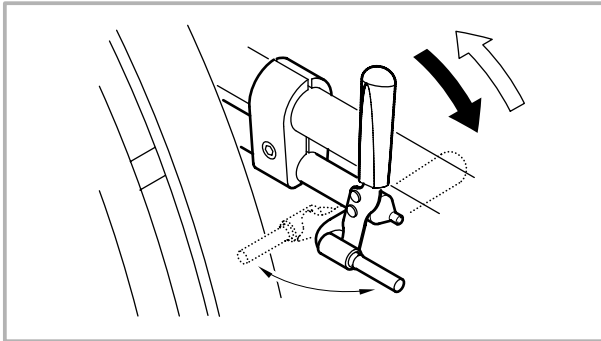

Figure 10

Applying the brake

- Push the brake lever forward until it reaches the stopper.

Releasing the brake

- Pull the braking lever back.

Active brake

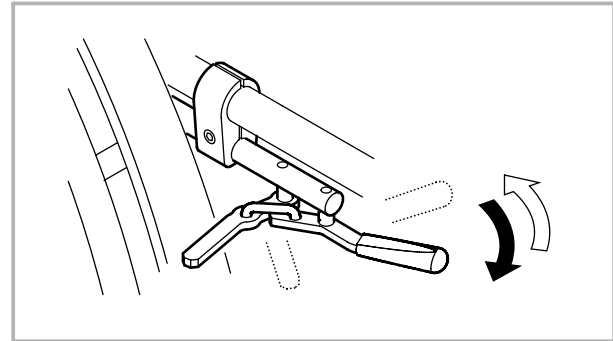

Figure 11

Applying the brake

- Pull the braking lever forward (beside or between your legs) until it reaches the stopper.

Releasing the brake

- Push the braking lever back (beside or between your legs).

3 Transporting the wheelchair



Your wheelchair is not suitable for use in vehicles. Do not sit on the wheelchair during a transport, use a properly secured seat.

Be careful when you remove the wheels from the wheelchair that you do not move the wheelchair on any abrasive surfaces (e.g. pulling over concrete). Excessive material abrasion could affect the strength of load-bearing parts.

3.1 Folding and unfolding the wheelchair

The wheelchair has a rigid frame. But the backrest can be folded down and fixed ("click") into position nonetheless.

Folding the wheelchair

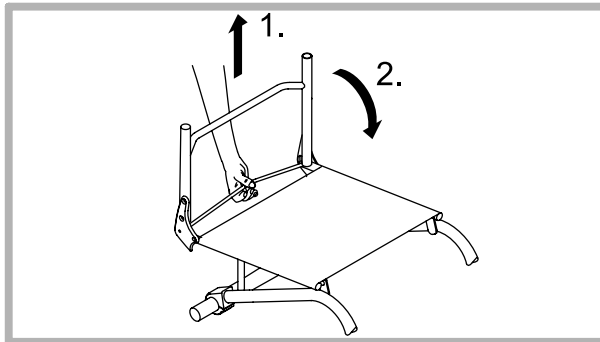

Figure 12

- Remove the seat cushion, if present.
- Flip clothes-guard inward to rest against backrest. (Both sides)
- Pull the pull-strap on the back of the wheelchair. (1.)
- Fold the backrest forward until it snaps into place. (2.)

The backrest bar of the wheelchair can now be used as a handle during transport.

Unfolding the wheelchair

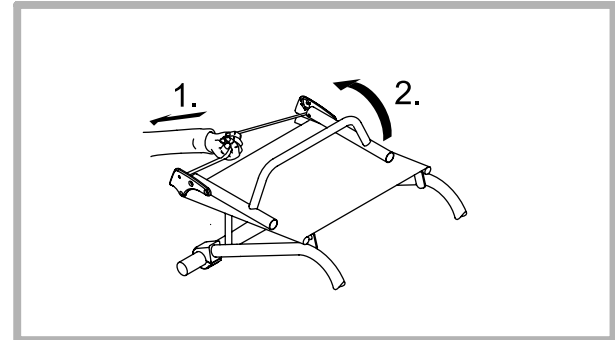

Figure 13

- Pull the pull-strap on the back of the wheelchair. (1.)
- Pull backrest by the backrest bar upwards until the backrest tubes on both sides of the frame snap into position. (2.)
- Reposition the clothes-guards.



Do not pull the backrest bar to open the backrest without pulling the pull-strap first.



Check that the backrest has really snapped into position (try to pull it to the front) before using the wheelchair.

3.2 Removing and installing the rear wheels

To reduce the size of your wheelchair, you can remove the rear wheels.

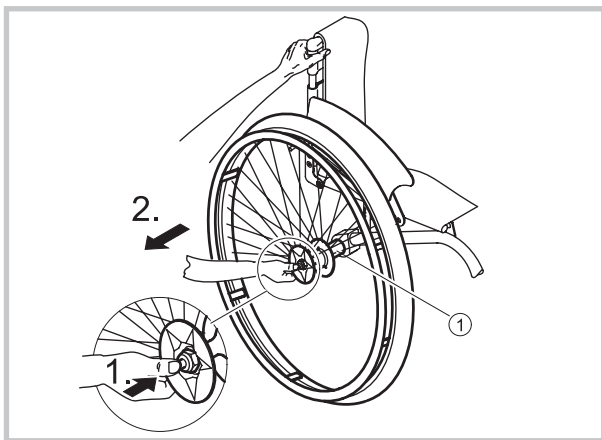

Figure 14

Removing the rear wheels

- Release the brakes.
- With one hand, hold the wheelchair in an upright position.
- With the other hand, hold the wheel at the spokes around the wheel hub (see Figure 14).

- Press the axle knob ① with your thumb and pull the wheel out of the adapter sleeve ②.

Installing the rear wheels

- Release the brakes.
- With one hand, hold the wheelchair in an upright position.
- With the other hand, hold the wheel at the spokes around the wheel hub (see Figure 14).
- Press the axle knob ① with your thumb, keep it pressed.
- Now insert the axle in the adapter sleeve ① of the axle tube until it comes to a rest.
- Release the axle knob. Now, the wheel fits tightly.



After fitting the wheels, always make sure that the removable axles are engaged completely. The head must be extended completely. Check by pulling the wheels outwards.

4 Adjustments and options



Ensure that when making any adjustments between the rear wheel and the clothing guard that there is sufficient room to avoid contusions/finger traps.

4.1 Adjusting the parking brakes

The parking brakes must be readjusted after adjusting the position of the rear wheels.

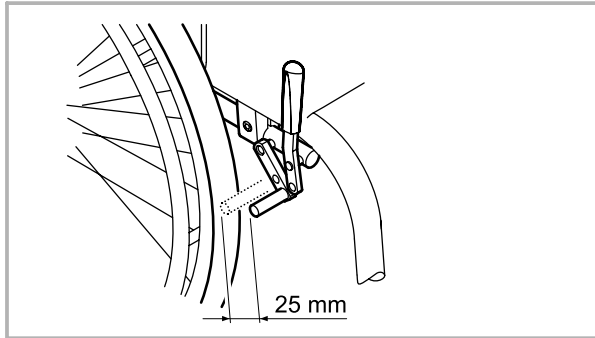

Figure 15

- Make sure that sufficient air is in the tyres. (see Chapter 5.2 - Maintenance).
- Loosen the hexagon socket bolt at the brake holder (hex. socket wrench 5mm), and move the brake to the required position.

With the brake applied, the brake shoe should not sink into the tyre more than 4 mm.



The function of the parking brakes is only ensured if sufficient air is in the tyre. (see Chapter 5.2 - Maintenance)

4.2 Adjusting the tension of the backrest cover

If your wheelchair is equipped with a backrest cover with adjustable tension, you can adjust the tension of the backrest cover to your individual requirements.

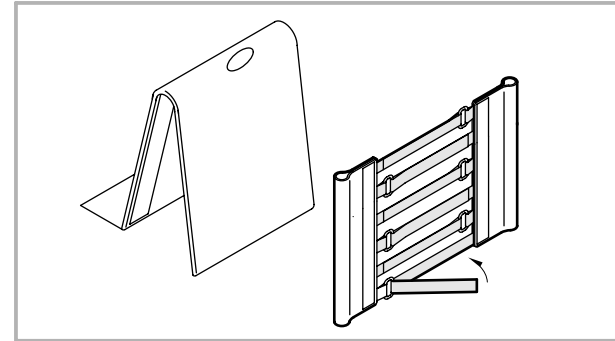

Figure 16

- Remove the backrest cushion.
- Loosen the Velcro® straps on the rear side of the seat cover, by simply pulling them off.
- Tighten or loosen the straps, as required, and fix them again.



Adjusting the backrest, see Chapter 6

4.3 Height adjustable push handles

The stepless height adjustable push handles allow pushing the wheelchair in a comfortable position. To ensure a maximum shoulder room for the wheelchair driver, the push handles are inclined backward.

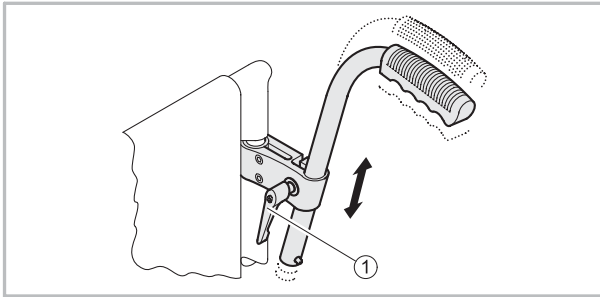

Figure 17

Adjusting the height of the push-handles:

- Loosen the locking bolt ①
- Move the handle to the required position
- Tighten the locking bolt again.

4.4 Foldable Push handles



Bild 18

Folding Push handles

- Hold wheelchair with one hand.
- Grasp the push handle with the other hand and press the trigger, which is hidden inside the rear of the hand grip, with the thumb.
- Pull the push handle back and fold down.

Unfolding push handle

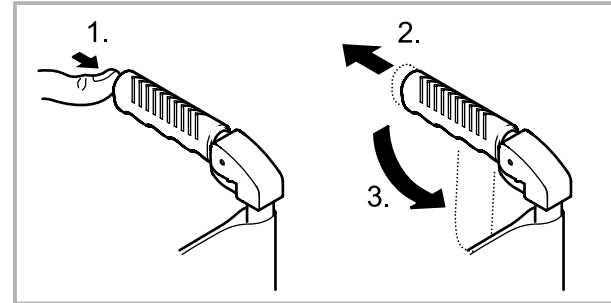
- Pull the push handle upwards into the horizontal, until it has snapped into place.



Certify that the push handles have actually been snapped into position, so that they cannot accidentally fold down again when pushing the wheelchair.

4.5 Armrest

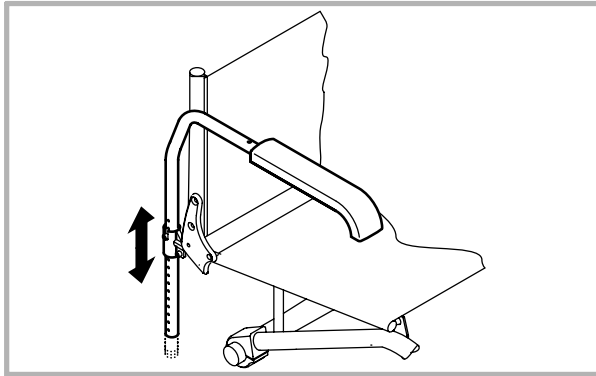

Figure 19

You can remove the armrest completely.

- Lift up the armrest and pull it out completely.

4.6 Mudguards

Removable mudguards can be mounted to the wheelchair to prevent dirt and mud from spraying from the rear wheels onto clothes when driving outdoors.

4.7 Transit wheels

If your wheelchair is too wide for certain applications (e.g. when travelling by train or airplane, or when driving in narrow aisles or through narrow doors), you can use the transit wheels.

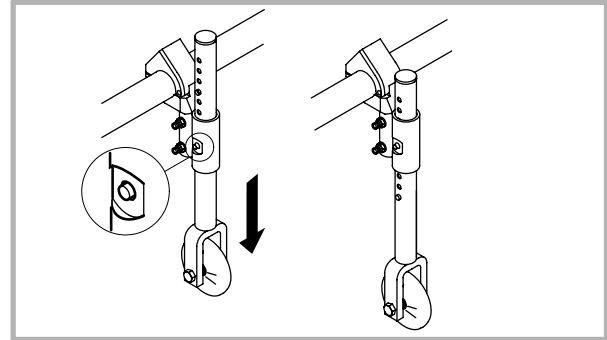

Figure 20

Change-over to transit wheels

- Move the transit wheels to their working position, by pushing the pin inward until you can pull down the tube. Push in the second pin, too, and pull the tube further down until the pin engages in the recess.



Check if the transit wheels are adjusted to the correct height. The distance to the floor must not exceed 2 cm.

- Move the wheelchair to an object that gives you a firm hold.
- Hold on to the object with one hand and incline the wheelchair until the rear wheel on the opposite side leaves the floor.

- Push your thumb on the head of the removable axle and pull the rear wheel out of the adapter sleeve.
- Lower the wheelchair again. Now it rests on the transit wheels on one side.
- Repeat the procedure for the other side.



Warning: Now, the parking brakes are no longer effective!

Warning: The wheelchair does not have the level of stability when transit wheels are mounted.

Change-over from transit wheels to rear wheels

- Move the wheelchair to an object that gives you a firm hold.
- Hold on to the object with one hand and incline the wheelchair until the transit wheel on the opposite side leaves the floor.
- Reinstall the rear wheel with the removable axle (also refer to Chapter 3.2 - Installing the rear wheels).
- Move the transit wheel to its parking position



After re-adjusting the transitwheels, please ensure that the clips are securely locked into position.

4.8 Antitipper

The Antitipper device prevents the wheel chair from tipping backward.

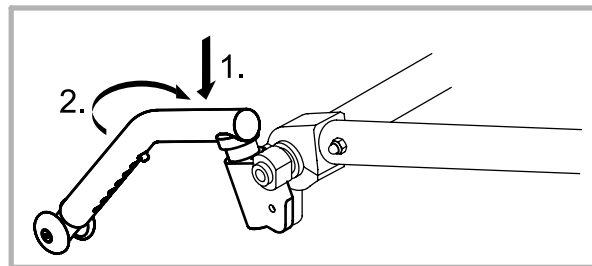

Figure 21

Activating the Antitipper

- Push the Antitipper down and swing outward until it engages.



In any case deactivate the Antitipper device before driving over a curbstone or a step. Danger of tipping!

Deactivating the Antitipper

- Slightly press the Antitipper down and swing inward. The device will swing away upward.

4.9 Security belt

Your wheelchair can be equipped with a security belt which prevents falling out of the wheelchair.

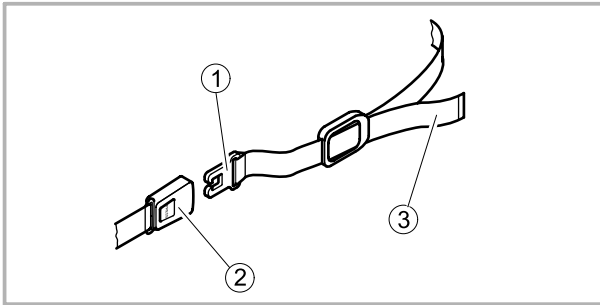

Figure 22

Belt assembly



The assembly of the belt should be carried out by your dealer!

- Pull the belt through the backrest and position it so that the buckle is placed at the front.

Opening the belt

- Press on the PRESS button and pull the locker ① out of its socket ②. The buckle will open up.

Closing the belt

- Insert the locker ① completely into the buckle socket ②.
- Pull the belt ③ until you are secured in the wheelchair.

4.10 Passive lighting

You can install two reflectors on the rear wheels.

4.11 Air pump

The air pump is delivered with a valve adapter. Depending on the size of the valve of your model, it may be necessary to turn the adapter at the air outlet of the pump.

- Remove the locknut
- Take out the valve adapter
- Turn it around and reinstall it
- Tighten the locknut again.

5 Service

5.1 Cleaning

The service life of your wheelchair increases if you maintain and clean it regularly.

Clean cushions and metal parts with a moist, soft cloth.

- Carefully dry your wheelchair after using it in rainy weather.



Sand and sea water may damage the ball bearings.

After using your wheelchair in a dirty environment, clean and dry it thoroughly as soon as possible.

Do not use rough scouring agents, aggressive cleaning agents or high-pressure cleaning machines.

5.2 Maintenance

We strongly advise that you should have your wheelchair thoroughly checked by the authorized dealer once a year, as a minimum. This is in addition to the general maintenance procedures detailed below.

In order to make sure that your wheelchair will give you the necessary safety and reliability over its whole service life, you should carry out the following work regularly, or have it carried out by your authorized dealer.

Maintenance plan

<i>Weekly</i>	<ul style="list-style-type: none">▪ Check air pressure in tyres▪ Check the proper fitting of the rear wheel axle in the sleeve
<i>Monthly</i>	<ul style="list-style-type: none">▪ Check bolted connections▪ Oil removable axles▪ Check tension of spokes
<i>Yearly</i>	<ul style="list-style-type: none">▪ General check by an authorized dealer

Measuring the air pressure

To ensure that the driving and braking function is maintained, it is important that the air pressure in the tyres is correct.

- Check weekly, if there is sufficient air in the tyres.

The optimum pressure values are indicated in the following table:

Type of tyre	Air pressure		
<i>Smooth-running tyres</i>	<i>7 bars</i>	<i>700 kPa</i>	<i>100 psi</i>
<i>Treaded tyres</i>	<i>7.5 bars</i>	<i>750 kPa</i>	<i>110 psi</i>
<i>Indoor sports tyre (Collé)</i>	<i>10 bars</i>	<i>1000 kPa</i>	<i>140 psi</i>
<i>Mountain bike tyre</i>	<i>4 bars</i>	<i>400 kPa</i>	<i>60 psi</i>
<i>Marathon Evolution tyre</i>	<i>10 bars</i>	<i>1000 kPa</i>	<i>140 psi</i>

If you are not sure about the tyres of your wheelchair, contact your authorized dealer.

Oiling the removable axles

To ensure the proper function of the removable axles, they must be oiled at regular intervals.

- Pour some resin-free bicycle oil on a cloth and slightly oil the balls at the end of the removable axles, the axle and the push-button.

Checking the bolted connections

Bolted connections may loosen if the wheelchair is used frequently.

- Check the bolts monthly for tight fit, re-tighten, if necessary.



Locknuts and locking bolts should be replaced if they become loose.

For replacement please contact an authorized dealer.

Repairing or replacing tyres

- Take off the wheel (see Chapter 3.2).
- Deflate the tyre by pressing on the valve.
- Lift one flank of the tyre off the wheel rim.



Use a bicycle tyre lever for this. Do not use sharp or pointed objects such as screw drivers in order to prevent the inner tube from being damaged.

- Pull the tube out of the tyre.
- Repair the tube using a bicycle tyre repair kit. If repairing is not possible, replace the tube.

Fitting tyres

- Inflate the tube slightly until it has its round shape.
- Insert the valve in the valve hole of the wheel rim and insert the tube in the tyre (the tube should be inside the tyre completely without folds).
- Starting at the valve push the tyre flanks over the edge of the wheel rim with both hands. Make sure that the tube is not jammed between the tyre and the wheel rim.



Use a bicycle tyre lever for this. Do not use sharp or pointed objects such as screw drivers in order to prevent the inner tube from being damaged.

- Pump the tyre up to the maximum operating pressure. Make sure that the tyre does not lose air anymore.

Spiderwheels

If the Spiderwheel starts squeeking then proceed as follows:

- Remove the wheel.
- Tighten the bolt in the wheelrim.

Spare parts

All spare parts are available at your authorized dealer.



To determine the size of a front wheel compare its outer diameter to the scale on the back of this manual.

5.3 Service life and disposal

We assume that our wheelchairs will be in use daily. For this reason the whole equipment is subjected to an almost continuous stress and, consequently, a natural wear and tear. Taking this into consideration and provided that the wheelchair is maintained properly, the lifetime of the Kuschall® wheelchairs is approximately 5 years. If the wheelchair is used less frequently, e.g. if you use it inside your apartment only, and if it is maintained perfectly, the service life will increase accordingly.

For proper disposal of your wheelchair, please contact your authorized dealer.

5.4 Detecting and repairing defects

The daily use of the wheelchair, new adjustments or changed requirements may result in defects which can be repaired.

We recommend that the adjustments should be carried out by your authorized dealer.

Defect	Possible cause	Remedy
<i>Wheelchair does not roll straight</i>	<i>Wrong air pressure in one of the rear wheels</i>	<i>Correct air pressure (Chapter 5.2)</i>
	<i>One or more spokes are broken</i>	<i>replace defective spoke(s)</i>
	<i>Spokes are not equally tightened</i>	<i>Tighten the loose-fitting spokes</i>
	<i>Front wheel bearings dirty or damaged</i>	<i>Clean or replace bearing</i>
<i>Wheelchair tips too easily</i>	<i>Rear wheel mounted too far to the front</i>	<i>Mount rear wheel further back (only possible with rear wheel extension) (Chapter 6.4)</i>
	<i>Backrest angle too large</i>	<i>Reduce backrest angle (Chapter 6.3)</i>
<i>Poor or asymmetric brake grip</i>	<i>Wrong air pressure in one or both rear wheels</i>	<i>Correct air pressure (Chapter 5.2)</i>
<i>Rolling resistance is very high</i>	<i>Rear wheels are off track</i>	<i>Change track</i>
	<i>Wrong air pressure in the rear wheels</i>	<i>Correct air pressure (Chapter 5.2)</i>
<i>Front wheels vibrate when driving fast</i>	<i>Tension at front wheel bearing block too low</i>	<i>Tighten nut at bearing block axle slightly</i>
<i>Seat cover loose</i>	<i>Fixation fatigued or ripped off</i>	<i>Replace seat cover</i>

5.5 Technical data

			75°	90°
GB	Total width ¹⁾	[cm]	52 - 62	
GL	Total length ²⁾	[cm]	83	76
SB	Seat width	[cm]	34 - 44	
SHv	Seat height front	[cm]	48 - 51	49 - 51
SHh	Seat height rear	[cm]	38 - 49	
SW	Seat angle	[cm]	variable	
ST	Seat depth	[cm]	35 - 50	
UL	Length of lower leg	[cm]	29 - 48	
RH	Backrest height	[cm]	27 - 48	
RLW	Backrest angle		74°, 78°, 82°, 86°, 90°	
	Weight ³⁾	[kg]	9.2	8.9
	Maximal load	[kg]	120	

¹⁾ GB = SB + 23 cm with rear wheel camber of 3° (+23 cm / 3°)

²⁾ Depends on seat level, length of lower leg, rear wheel and position of footrest

³⁾ With standard configurations can vary (+/-)

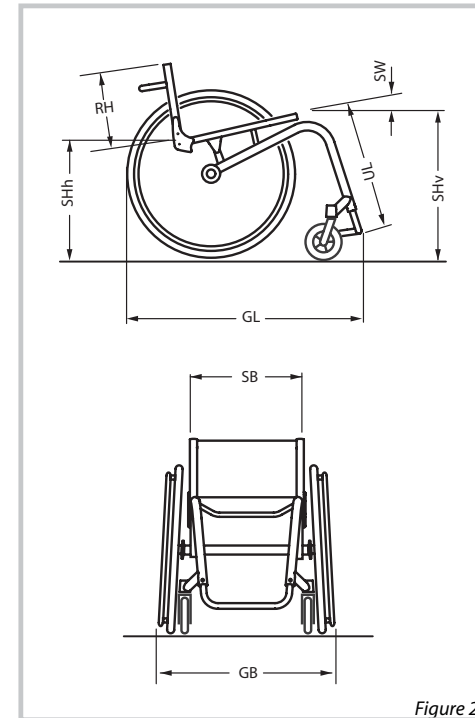

Figure 2.3

5.6 Warranty conditions

Standard terms

This is to certify that your wheelchair is warranted by Kuschall® for a period of 24 month for all parts except wear parts. For further information about the warranty period please contact the Kuschall® distributor in your country (see back page of this manual)

The warranty is subject to the following conditions:

1. Only kuschall® wheelchairs purchased at full price are warranted against defective workmanship and materials.
2. If a defect or fault is discovered the Kuschall® dealer from whom the appliance was purchased should be notified immediately.
3. The manufacturer will not accept responsibility for damage caused by misuse or the non-observance of the instructions set out in the user manual.
4. During the period of warranty, any parts that have become defective due to faulty workmanship or materials, will be renewed or repaired free of charge by the Kuschall® dealer.
5. The warranty will be forfeited should any unauthorised alteration be made to the equipment.
6. The purchaser's statutory rights under the consumer Protection Act are not affected.
7. If the purchaser mounts additional adaptations to their Kuschall® wheelchair, they must obtain a written authorization from Kuschall AG. Otherwise any possible liability claims cannot be asserted.

Limitation of liability

This warranty does not extend to the consequential costs resulting from fault clearance, in particular freight and travel costs, loss of earnings, expenses, etc.

Kuschall® shall not be liable for:

- natural wear and tear
- inappropriate and incorrect use
- defective assembly or setting up the purchaser or third parties
- defective or neglectful treatment
- use of unsuitable spares.

6 Adjustments carried out by the authorized dealer



This chapter is expressly intended for trained authorized dealers.

Authorized dealers should inspect the wheelchair thoroughly for wear or damage and replace components as necessary

Minor changes may have great effects on the seat position and the driving behaviour and thus the safety. Since many adjustments influence each other, sufficient product know-how and technical experience is required in order to carry out these adjustments properly.

We recommend that you have all adjustments and repair work described in this section carried out by an authorized KÜSCHALL® dealer.



For your local authorized dealer, please contact the KÜSCHALL® representation in your country (see back of this user manual).

6.1 Back height adjustment

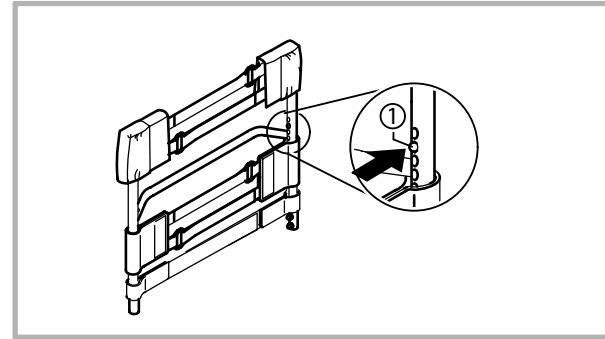

Figure 24

- Remove the adjustable backrest cover and the top Velcro® band.
- Slide the remaining Velcro® bands up or down, until the spring clip ① positioned in one of the holes is visible.
- Press the spring clip ① into the tube.
- Adjust the backrest tube up or down into the required position.
- Repeat this procedure on the other side of the backrest.
- Attach the Velcro® band and re-assemble the adjustable backrest cover.

6.2 Backrest angle adjustment

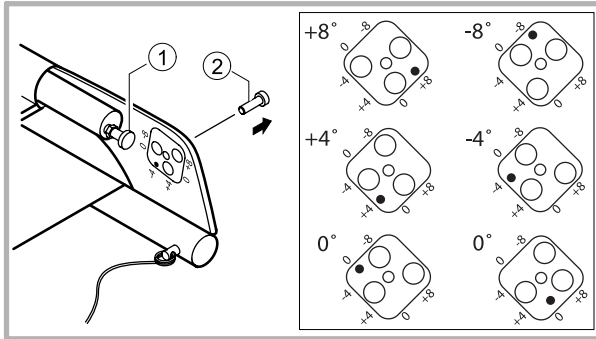

Figure 25

- Fold down backrest, loosen the counter nut of the placement bolt ① and tighten the bolt completely.
- Loosen the lens head bolt ②.
- Remove excenter, turn or flip and turn to create correct angle.
- Replace and retighten bolt ②.
- Open the backrest up, until the bolts click into place. Unscrew the placement bolt ① until it rest against the frame and the backrest joint no longer has any leeway.
- Retighten the counter nut.



The position of the backrest angle must be the same on both sides of the chair.

6.3 Vario-Ax Adjustment

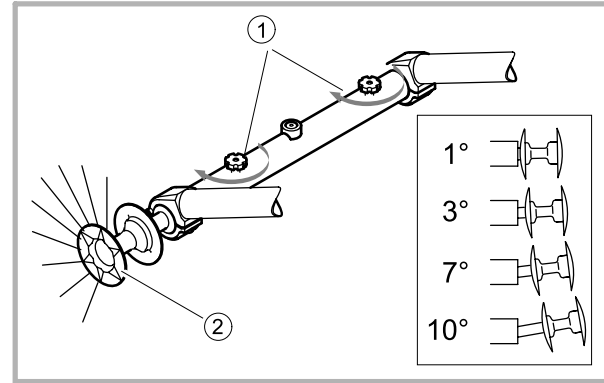

Figure 26

- Loosen the knurled head screw ① on the Vario-Ax.
- Pull the wheel at the hub ② until the required camber is reached. The possible calibrations are 1, 3, 7 and 10 degrees.
- Ensure the required camber has been latched in correctly.
- Re-tighten the knurled head screw.



Do not tighten the knurled head screw to hard, the mechanism will otherwise block and break.

Please note that the parking brakes will no longer function with a camber alteration of more than 2 steps (ex from 1° to 10°).

6.4 Rear Wheel Position

The rear wheel position can be adjusted when a rear wheel extension is mounted. The further back you mount the adapter sleeve, the higher the tipping safety of the wheelchair is.

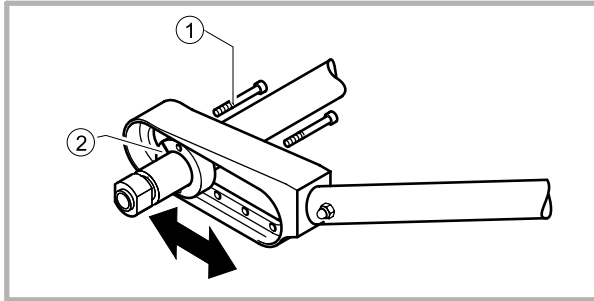

Figure 27

- Remove bolt ① from both sides of the rear wheel extension (allen key 4mm).
- Slide the camber bar along the rear wheel extension to the required position.
- Tighten bolts ①.



After adjustment tighten all bolts firmly.

The parking brakes must be readjusted after alterations are made to the rear wheel position.



Küschall AG
Benkenstrasse 260
CH-4108 Witterswil

Your authorized dealer:

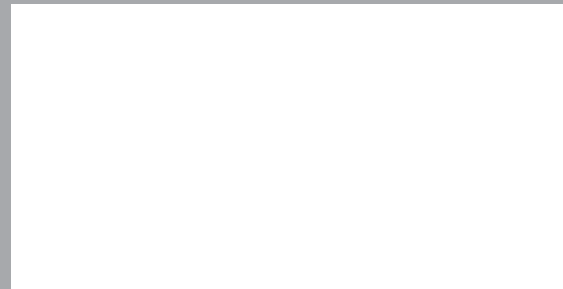

küschall® distributors:

Belgium & Luxemburg: Invacare · Autobaan 14 · B-8210 Loppem

Danmark: Invacare A/S · Sdr. Ringvej 39 · DK-2605 Brøndby

Deutschland & Ost Europa: Invacare Aquatec · Alemannenstraße 10 · D-88316 Isny

Ireland: Invacare Ltd. · Unit 5, Seatown Business Campus · Seatown Road · Swords, Co. · County Dublin

España: Invacare S.A. · c/ Areny · s/n Polígon Industrial de Celrà · E-17460 Celrà (Girona)

France: Invacare Poirier SAS · Route de St Roch · F-37230 Fondettes

Italia: Invacare Mecc San s.r.l. · Via dei Pini 62 · I-36016 Thiene (VI)

Nederland: Invacare B.V. · Celsiusstraat 46 · NL-6716 BZ Ede

Norge: Invacare AS · Grensesvingen 9 · N-0603 Oslo

Portugal: Invacare (Portugal), Lda · Rua Senhora de Campanhã 105 · P-4369-001 Porto

Schweiz, Österreich & Middle East: Küschall AG · Benkenstrasse 260 · CH-4108 Witterswil

Sverige & Finland: Invacare AB · Fagerstagatan 9 · P.O. Box 66 · S-163 91 Spånga

United Kingdom: Invacare Ltd. · South Road · Bridgend Industrial Estate · Bridgend CF31 3PY · UK

www.kuschall.com

The küschall® brand is a registered trademark.

Every effort has been made to ensure that the contents of this publication are fully up-to-date at the time of going to print. As part of its ongoing improvement of products, Küschall AG reserves the right to modify existing models at any time. küschall® dealers will be notified of any such modifications. Any use of this publication, of parts thereof, as well as any reproduction of images, must have the written consent of Küschall AG.

